



International Journal of Multidisciplinary Research and Development



IJMIRD 2014; 1(5): 154-164
www.allsubjectjournal.com
Received: 01-10-2014
Accepted: 13-10-2014
e-ISSN: 2349-4182
p-ISSN: 2349-5979
Impact Factor: 3.762

S. Ramesh Kumar Babu
M. Tech Student
Department of Mechanical
Engineering, QIS College of
Engineering & Technology
Ongole – 523272, Andhra
Pradesh, India.

Venkata Ramesh Mamilla
Professor, Department of
Mechanical Engineering, QIS
College of Engineering &
Technology, Ongole – 523272,
Andhra Pradesh, India.

Correspondence:
S. Ramesh Kumar Babu
M. Tech Student
Department of Mechanical
Engineering, QIS College of
Engineering & Technology
Ongole – 523272, Andhra
Pradesh, India.

Crash test analysis of impact barrier using honey comb textile and other geometry's

S. Ramesh Kumar Babu, Venkata Ramesh Mamilla

Abstract

Textile honeycomb composites, with an array of hexagonal cells in the cross section, is a type of textile composites having the advantage of being light weight and energy absorbent over the solid composite materials. The aim of this project is to investigate the influence of the geometric parameters on textile honeycomb composites on their mechanical performances under low velocity impact, which can be used to help designer control over the textile honeycomb composites.

The 3D honeycomb fabrics are successfully manufactured and converted into textile honeycomb composites. It was found through the finite element analysis (FEA) that changes in geometric and structural parameters of the textile honey comp composites have noted influences on the energy absorption, force attenuation and damage process of the structure.

This project carries the comparison between honeycomb, hexagonal, box, triangular and cross triangular composite shapes for optimized inner core design based on FEA based impact analysis to rectify the delamination problems occurring in honey comb technology due to impacts (even small impacts).

Keywords: Crash Test Analysis; Impact Barrier; Honey Comb Textile.

1. Introduction

The Washington State Department of Transportation (WSDOT) uses traffic barriers to reduce the overall severity of collisions that occur when a vehicle leaves the traveled way. Consider whether a barrier is preferable to the recovery area it replaces. In some cases, installation of a traffic barrier may result in more collisions, as it presents an object that can be struck. Barriers are designed so that such encounters might be less severe and not lead to secondary or tertiary collisions. However, when impacts occur, traffic barriers are not guaranteed to redirect vehicles without injury to the occupants or additional collisions. Barrier performance is affected by the characteristics of the types of vehicles that collide with them. For example, motor vehicles with large tires and high centers of gravity are commonplace on our highways and they are designed to mount obstacles. Therefore, they are at greater risk of mounting barriers or of not being decelerated and redirected as conventional vehicles would be.

When barriers are crash-tested, it is impossible to replicate the innumerable variations in highway conditions. Therefore, barriers are crash-tested under standardized conditions. These standard conditions were previously documented in National Cooperative Highway Research Program (NCHRP) Report 350. These guidelines have been updated and are now presented in the Manual for Assessing Safety Hardware (MASH).

Barriers are not placed with the assumption that the system will restrain or redirect all vehicles in all conditions. They are placed with the assumption that under normal conditions, they might provide an improved safety condition for most collisions. Consequently, barriers should not be used unless an improved safety situation is likely. No matter how well a barrier system is designed, optimal performance is dependent on drivers' proper use, maintenance, and operation of their vehicles and the proper use of vehicle restraint systems.

At the time of installation, the ultimate choice of barrier type and placement is made by gaining an understanding of site and traffic conditions, having a thorough understanding of and using the criteria presented in Chapters 1600 and 1610, and using engineering judgment. Xiaozhou Gong^[1] Cellular solids such as sandwich panels have been used as advanced materials in aerospace, automobile and marine industries for decades due to their unique combination of properties derived from their cellular structures.

Scientists and engineers have paid more and more attentions to cellular solids since new techniques for making ceramic and metallic foams have widened the range of man-made materials and the diversity of their applications. Textile reinforced honeycomb composite can be regarded as a kind of cellular solid due to its hollow core structure and as an innovative product, much interests have been drawn on it to find out its mechanical performance under various loading conditions.

This presents a literature review on cellular solids including textile honeycomb composites in the following aspects, which are (1) classification, applications, mechanical and non-mechanical features of cellular solids (2) honeycomb structure manufacturing techniques (3) the mechanical performances of cellular solids under various impact conditions (4) the energy absorption analysis of cellular solids (5) the basic concept of three-dimensional (3D) fabrics and structural parameters for textile honeycomb composite (6) the application of 3D honeycomb fabrics on personal protection equipment (PPE).

Thomas Jost *et al.* ^[2] Using Finite Element (FEM) it is possible to show and predict the behavior of the vehicles structure during a crash test. To ensure good simulation results compared to the reality it is not only necessary to carry out built up the FE-model of the vehicle, but to simulate the real behavior of the crash barrier too. To meet this demand a new method for modeling and simulating crash barrier has been developed. This method is based on discrete beam elements to model the aluminum honeycomb structure. The major advantage of this method is the possibility to show realistic local and global deformation behavior of honeycomb structures that include all characteristics deformation models. To ensure high quality crash barrier models an effort was done on testing and validating. Over all, the results of the validation work shows a good accordance of the acceleration, the force results and of the deformation behavior of all structures

Mehrdad Asadi *et al.* ^[3] The offset deformable barrier (ODB) has been used by Euro NCAP and most of leading car manufacturers worldwide. This deformable barrier is used for frontal offset impact while the specifications while the specifications developed by EEVC WGII. This paper represents the methodology to create the advanced FE Model of cell bonds ODB barrier and certification through experimental test data. LS-Dyna was used to analyze the FE Model and a number of static compressive tests performed at different angles to construct aluminum honeycomb material cards. The strain-rate factor curves are also defined to simulate stiffening in the aluminum honeycomb during the analysis. Adhesive properties are obtained using climbing Drum, T-Peel, Tensile and Plate shear test results. The initial component test generated a good correlation with FE output and to validate the barrier model, similar impact test were performed in LS-Dyna environment respecting of four. In all assessments the barriers were mounted on a rigid wall and were tested at certain impact speeds. The final comparison on overall results represents a good correlation between that data and CAE results for all tests.

Z.Q. Chenga *et al.* ^[4] The experiences encountered during the development, modification, and refinement of a "finite element model of a four-door sedan are described. A single model is developed that can be successfully used in

computational simulations of full frontal, offset frontal, side, and oblique car-to-car impacts. The simulation results are validated with test data of actual vehicles. The validation and computational simulations using the model show it to be computationally stable, reliable, repeatable, and useful as a crash partner for other vehicles.

T. J. Stevenson ^[5] The literature on vehicle crash reconstruction provides a number of empirical or classical theoretical models for the distance pedestrians are thrown in impacts with various types of vehicles and impact speeds. The aim of this research was to compare the predictions offered by computer simulation to those obtained using the empirical and classical theoretical models traditionally utilized in vehicle-pedestrian accident reconstruction. Particular attention was paid to the pedestrian throw distance versus vehicle impact speed relationship and the determination of pedestrian injury patterns and associated severity.

It was discovered that computer simulation offered improved pedestrian kinematic prediction in comparison to traditional vehicle-pedestrian accident reconstruction techniques. The superior kinematic prediction was found to result in a more reliable pedestrian throw distance versus vehicle impact speed relationship, particularly in regard to varying vehicle and pedestrian parameters such as shape, size and orientation. The pedestrian injury prediction capability of computer simulation was found to be very good for head and lower extremity injury determination. Such injury prediction capabilities were noted to be useful in providing additional correlation of vehicle impact speed predictions, whether these predictions were made using computer simulation, traditional vehicle-pedestrian accident reconstruction methods or a Combination of both.

A generalized approach to the use of computer simulation for the reconstruction of vehicle-pedestrian accidents was also offered. It is hoped that this approach is developed and improved by other researchers so that over time guidelines for a standardized approach to the simulation of vehicle-pedestrian accidents might evolve. Thoracic injury prediction, particularly for frontal impacts, was found to be less than ideal. It is suspected that the relatively poor thoracic bio fidelity stems from the development of pedestrian mathematical models from occupant mathematical models, which were in turn developed from cadaver and dummy tests. It is hoped that future research will result in improved thoracic bio fidelity in human mathematical models.

A. B. Doyum *et al.* ^[6] In this study, effectiveness and sensitivity of ultrasonic through transmission C-scan and X-ray radiography methods for the characterization and classification of defects unique to honeycomb structures were analyzed. The specimens with built-in defects were fabricated and tested by Automated Ultrasonic Scanning System (AUSS) and X-ray film radiography. AUSS provides significant information which can be used to identify and size most of the defects such as planar voids, core damages and water/hydraulic fluid intrusion into the core. X-ray radiography was found to be a reliable NDI technique for defects such as core damages, water/hydraulic fluid intrusion into core and air gaps that might occur in filler adhesive. When used together, these two techniques were found sufficient for the detection and characterization of most defects encountered in honeycomb structures.

Thomas R. Hay *et al.* [7] Guided wave inspection of composite skin-honeycomb core structures is an efficient and sensitive alternative to other common inspection methods. This paper shows that sweeping experimentally through the dispersion curves is an effective way to experimentally locate guided wave modes sensitive to skin-core delamination. Composite skin-Nomex honeycomb core specimens were developed with simulated delaminated areas. The delaminated areas were detected with guided waves and confirmed with conventional ultrasonic testing

methods. Calculated phase velocity dispersion curves are given to define the practical phase velocity and frequency ranges. Example wave structures in this range are given to illustrate the change in sensitivity as frequency is swept for a given mode.

2.0 Barrier Design

2.1 Modeling of Traditional hexagonal cross-sectioned impact barrier Honeycomb

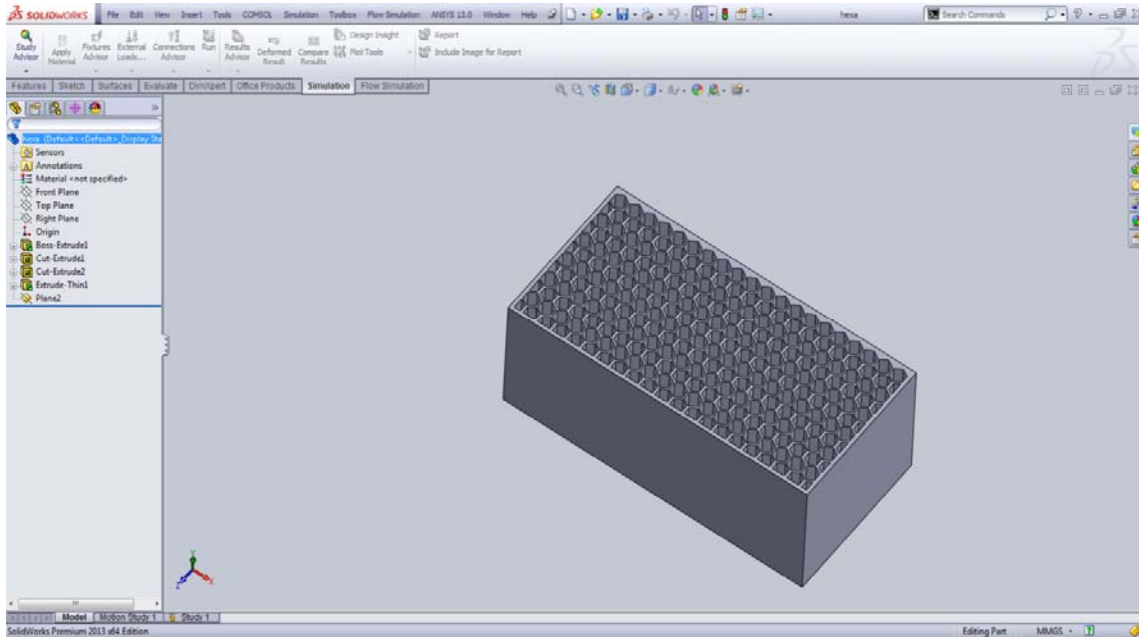

Fig 1: Traditional hexagonal cross-sectioned impact barrier Honeycomb Structure

2.2 Modeling of Square cross-sectioned impact barrier Honeycomb Structure using

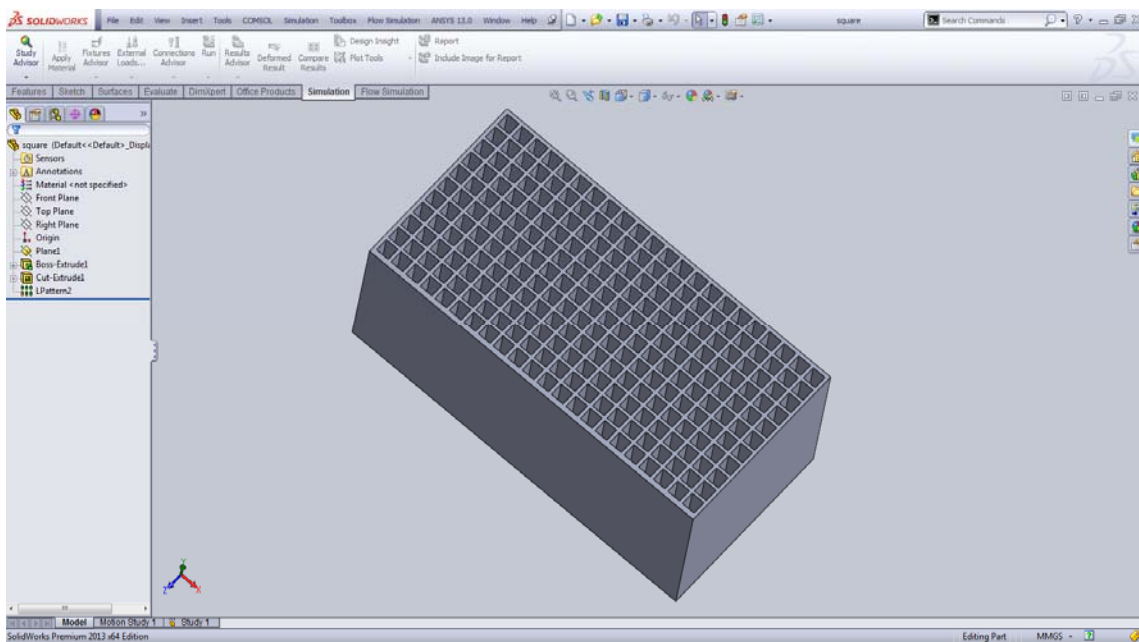

Fig 2: Square cross-sectioned impact barrier

2.3 Modeling of Triangular cross-sectioned impact barrier Honeycomb Structure

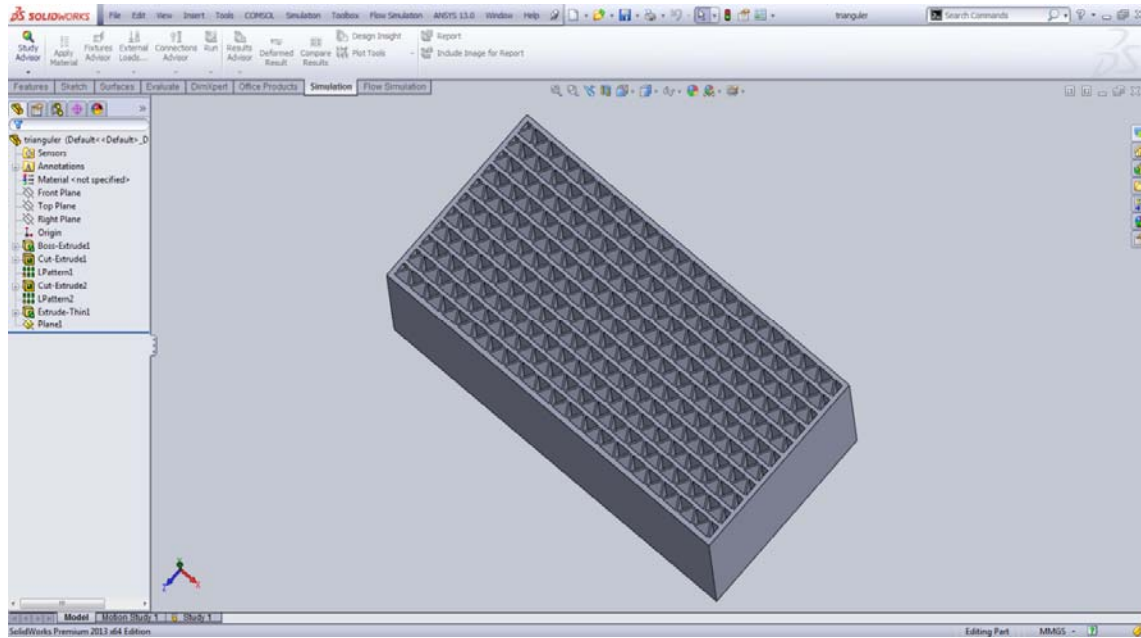

Fig 3: Triangular cross-sectioned impact barrier

2.4 Modeling of Cross-triangular –cross sectioned impact barrier Honeycomb Structure

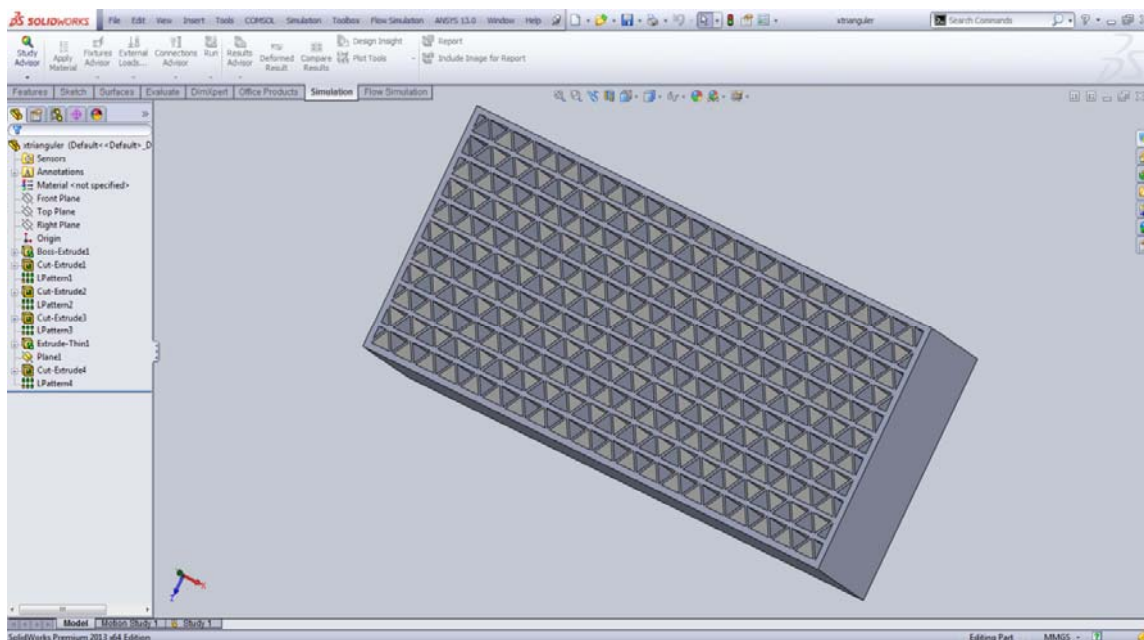

Fig 4: Cross-triangular cross-sectioned impact barrier

3.0 Load Conditions

When barriers are crash-tested, it is impossible to replicate the innumerable variations in highway conditions. Therefore, barriers are crash-tested under standardized conditions. These standard conditions were previously documented in National Cooperative Highway Research Program (NCHRP) Report 350. These guidelines have been updated and are now presented in the Manual for Assessing Safety Hardware (MASH).

As per the above discussion we are going to conduct analysis at speed of 250 kmph = 69.44M/S

4.0 IMPACT ANALYSIS

4.1 Hexagonal (E-Glass)

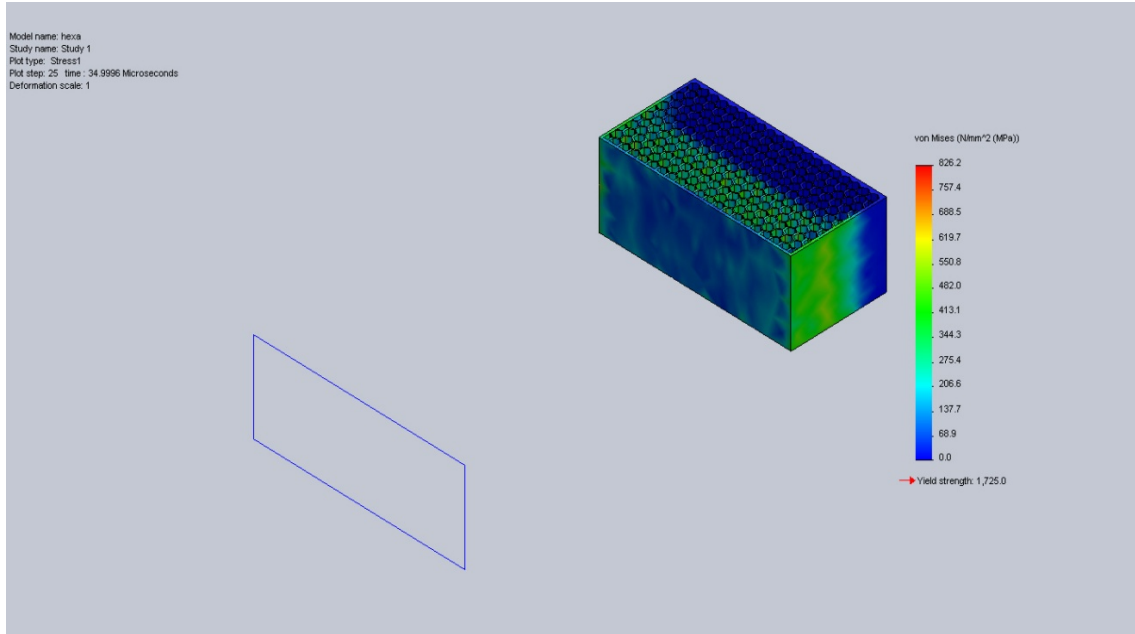

Fig 5: Von misses stress value, Min = 2.17743e-006 N/mm² (MPa), Max = 826.247 N/mm² (MPa)

4.2 Hexagonal (S2-Glass)

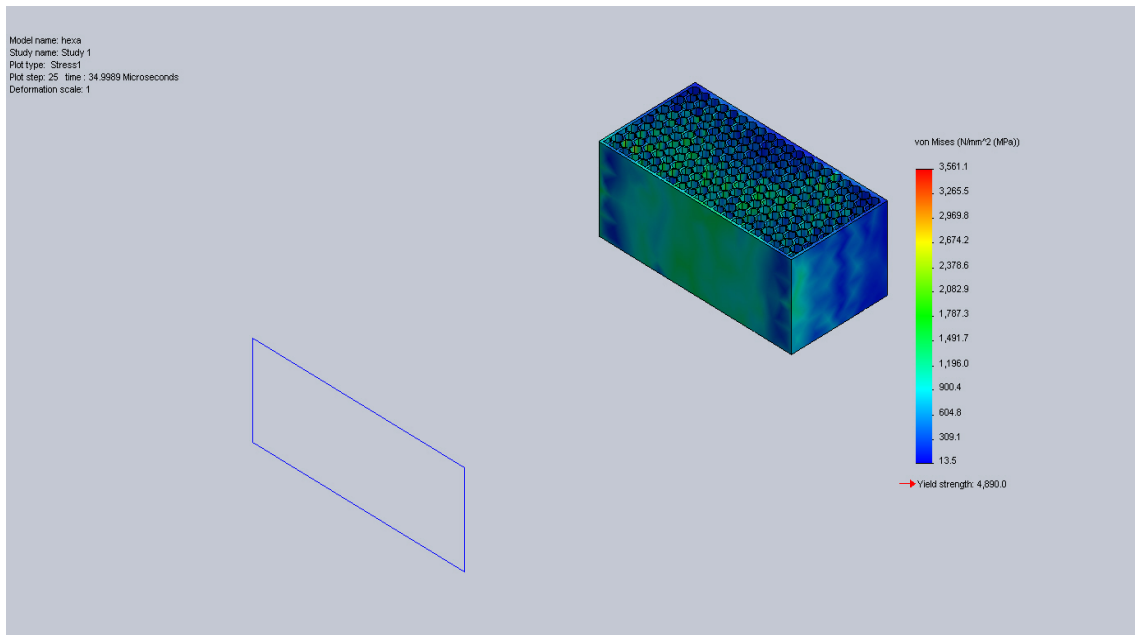

Fig 6: Von misses stress value, min = 13.5071 N/mm² (MPa), max = 3561.1 N/mm² (MPa)

4.3 Hexagonal (aluminum)

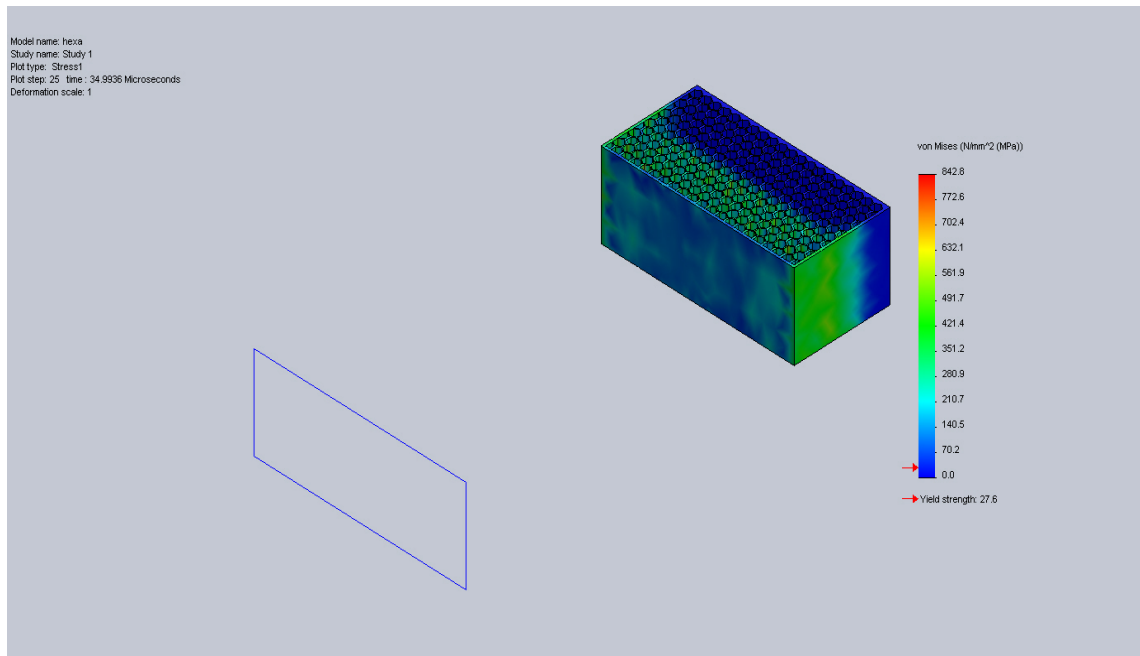

Fig 7: Von misses stress value, min = 2.47172e-006 N/mm², Max = 842.841 N/mm²

4.4 Square (E-Glass)

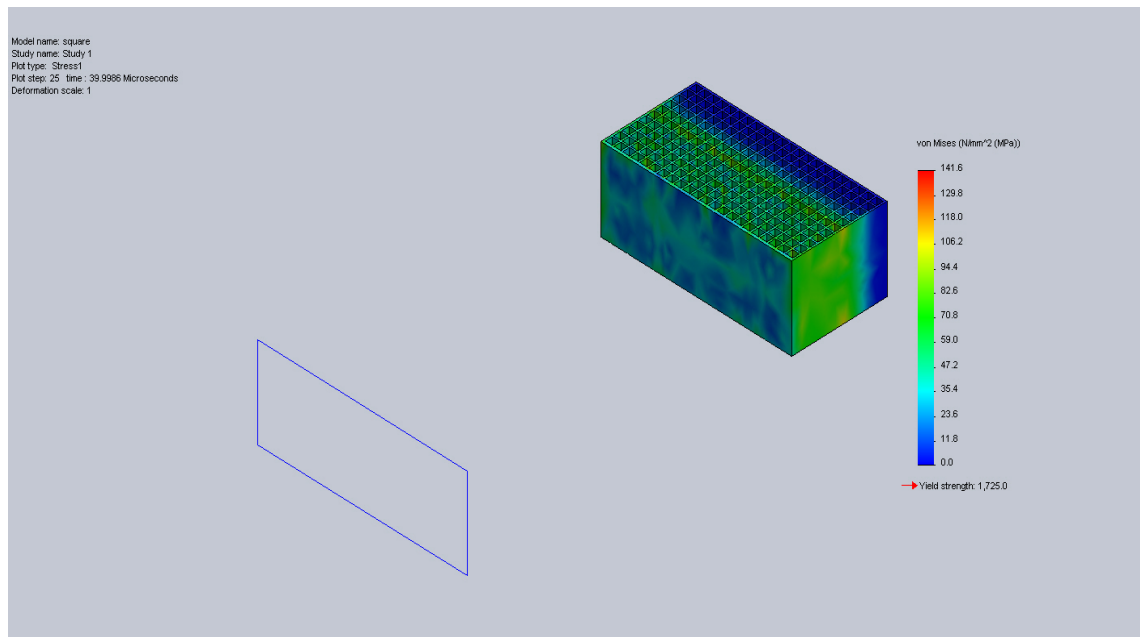

Fig 8: Von misses stress value, min = 0.000828085 N/mm²,
max = 141.632 N/mm² (MPa)

4.5 Square (s2-glass)

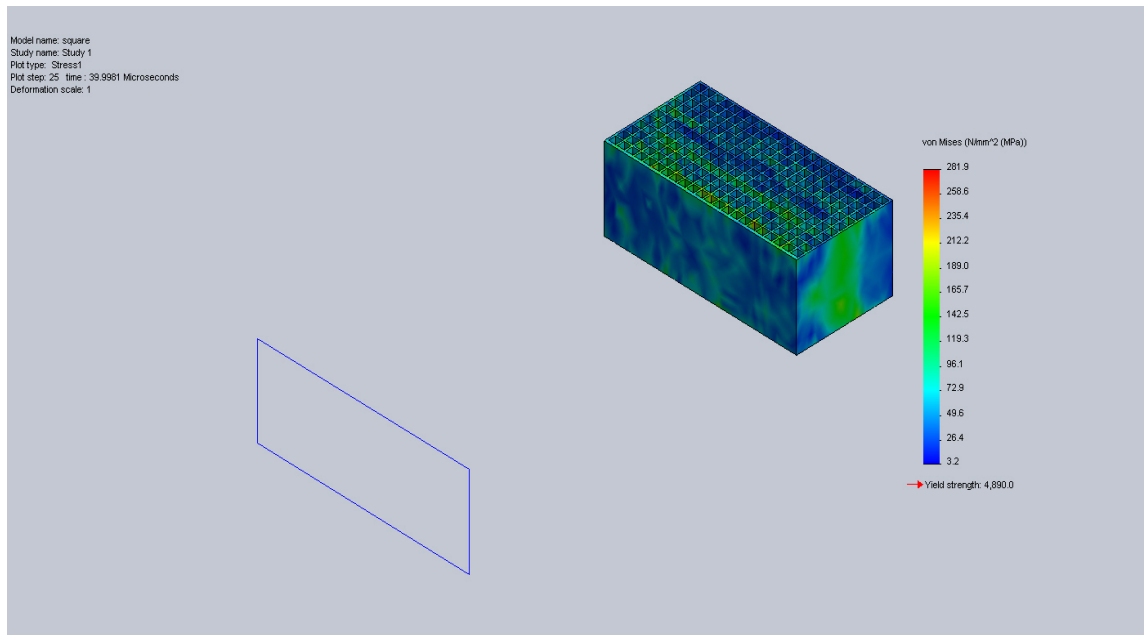

Fig 8: Von misses stress value, Min = 3.19176 N/mm² (MPa),
Max = 281.863 N/mm² (MPa)

4.6 Square (aluminum)

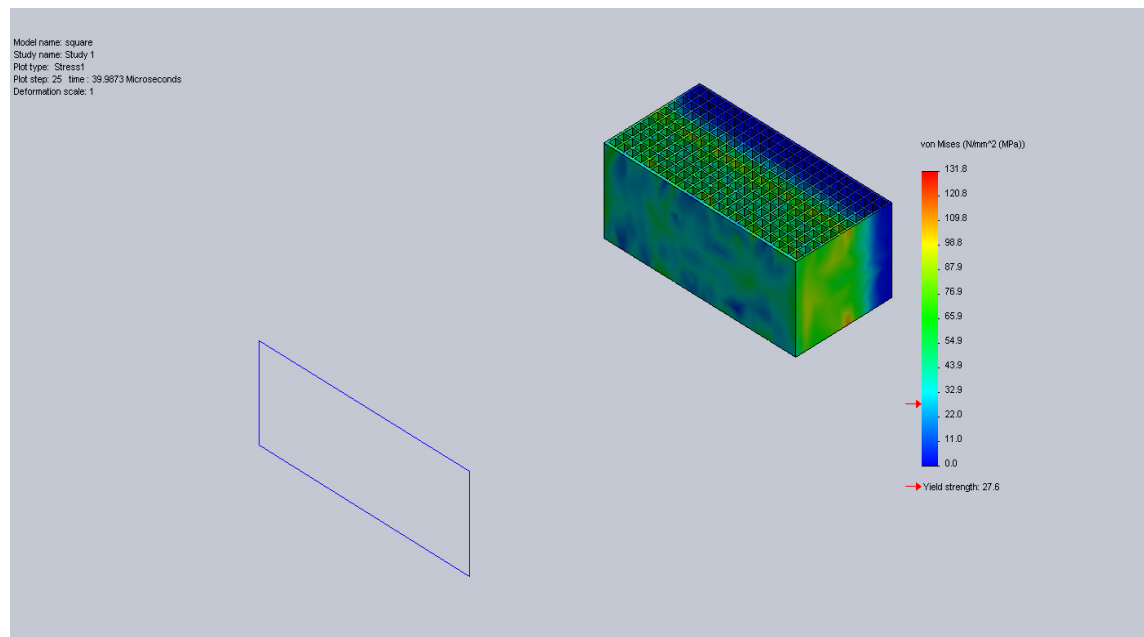

Fig 9: Von misses stress value, Min = 0.00132973 N/mm²,Max =131.796 N/mm²
4.7 Triangular (e-glass)

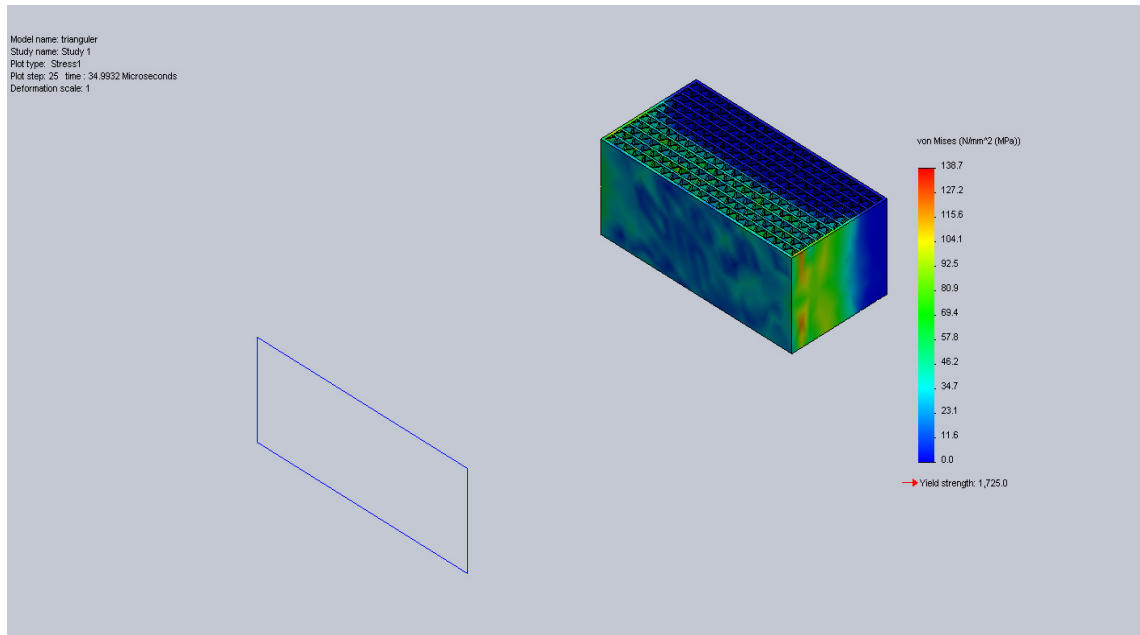

Fig 10: The above image shows the Von misses stress value, min = $6.60734e-005$ N/mm², max = 138.738 N/mm² (MPa) 4.8 Triangular (s2-glass)

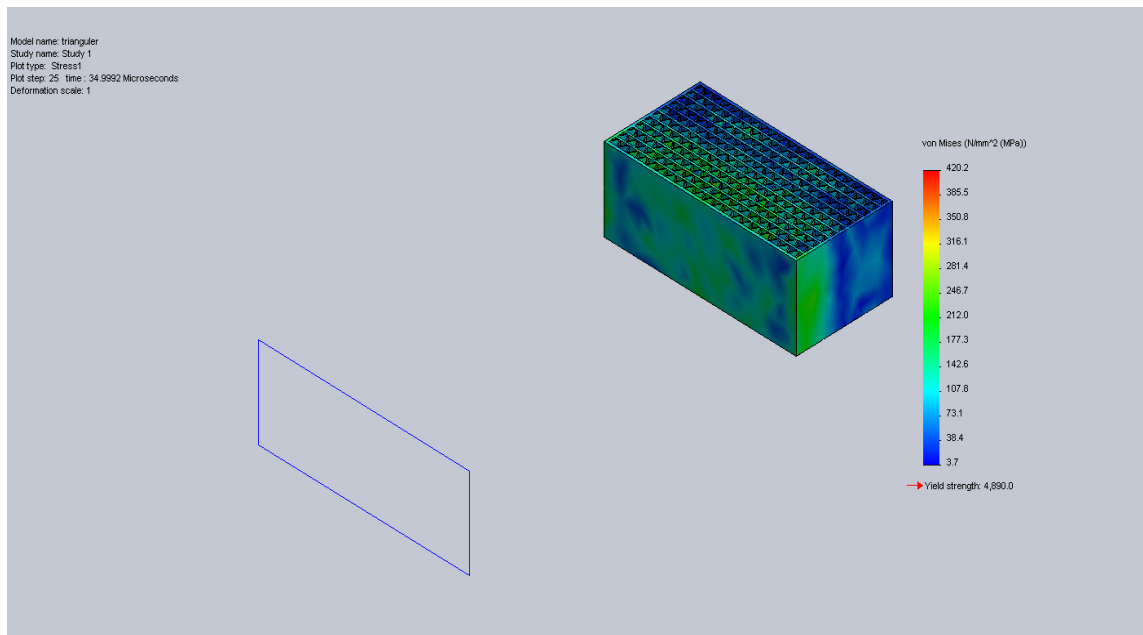

Fig 11: Von misses stress value, Min = 3.71096 N/mm² (MPa), Max = 420.233 N/mm² (MPa)

4.9 Triangular (Aluminum)

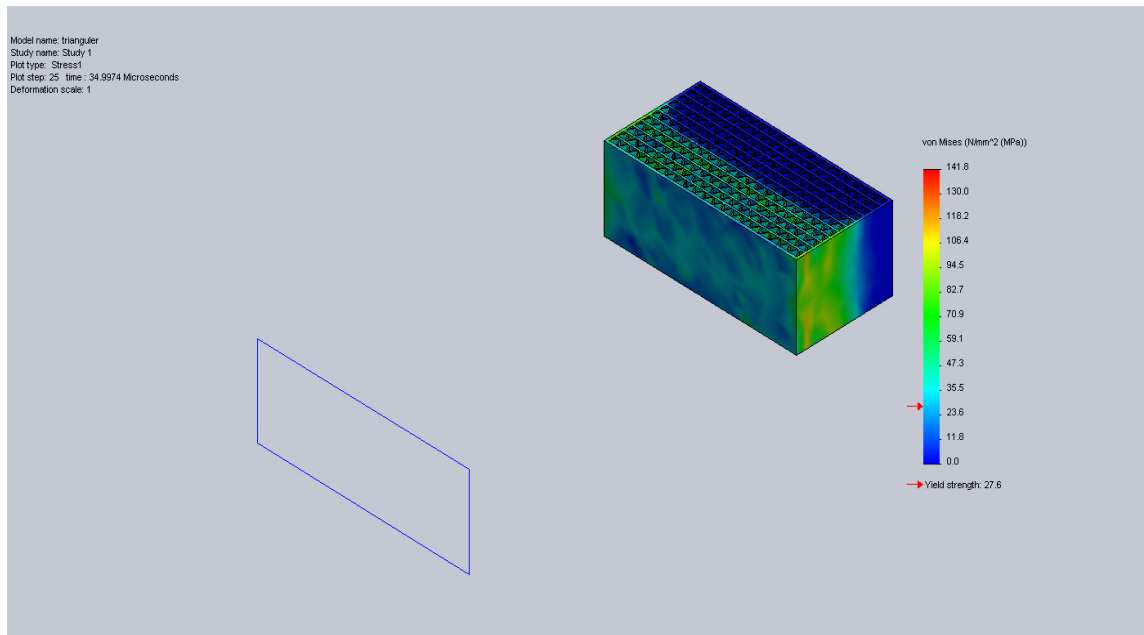

Fig 12: Von misses stress value, Min = 6.7617e-005 N/mm²,Max = 141.817 N/mm²

4.10 Cross Trianguler (e-glass)

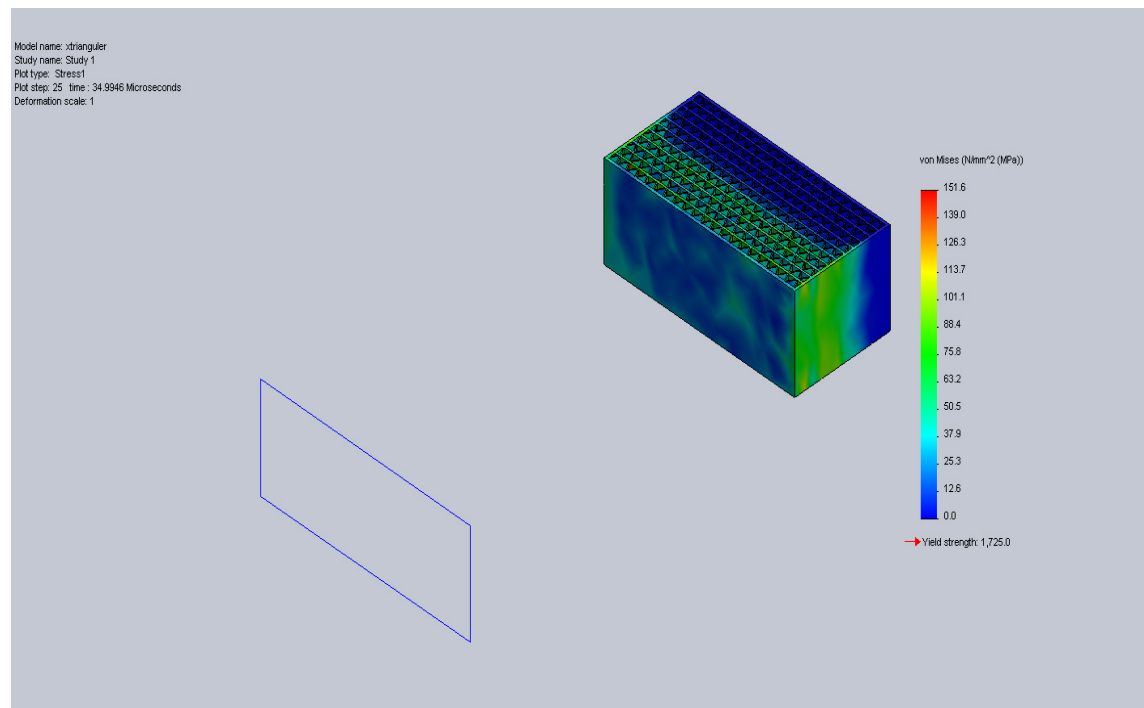

Fig 13: Von misses stress value, Min = 0.000466547 N/mm², Max = 151.585 N/mm² (MPa)

4.11 Cross Trianguler (s2-glass)

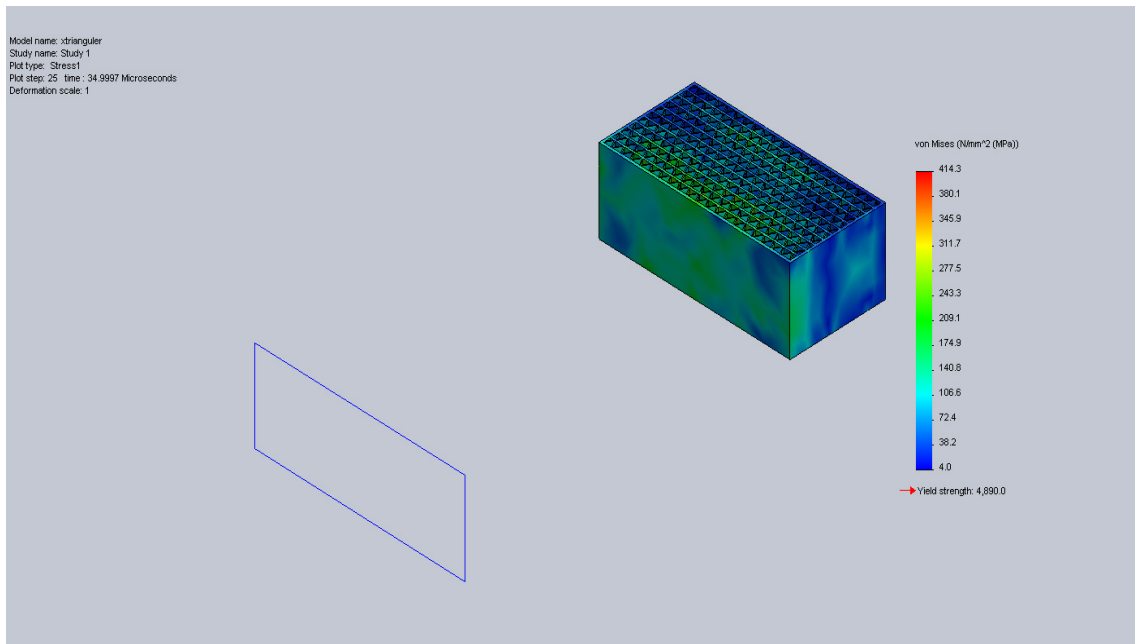

Fig 14: Von misses stress value, Min=3.99259 N/mm² (MPa), Max=414.289 N/mm² (MPa)

4.12 Cross Trianguler (Aluminum)

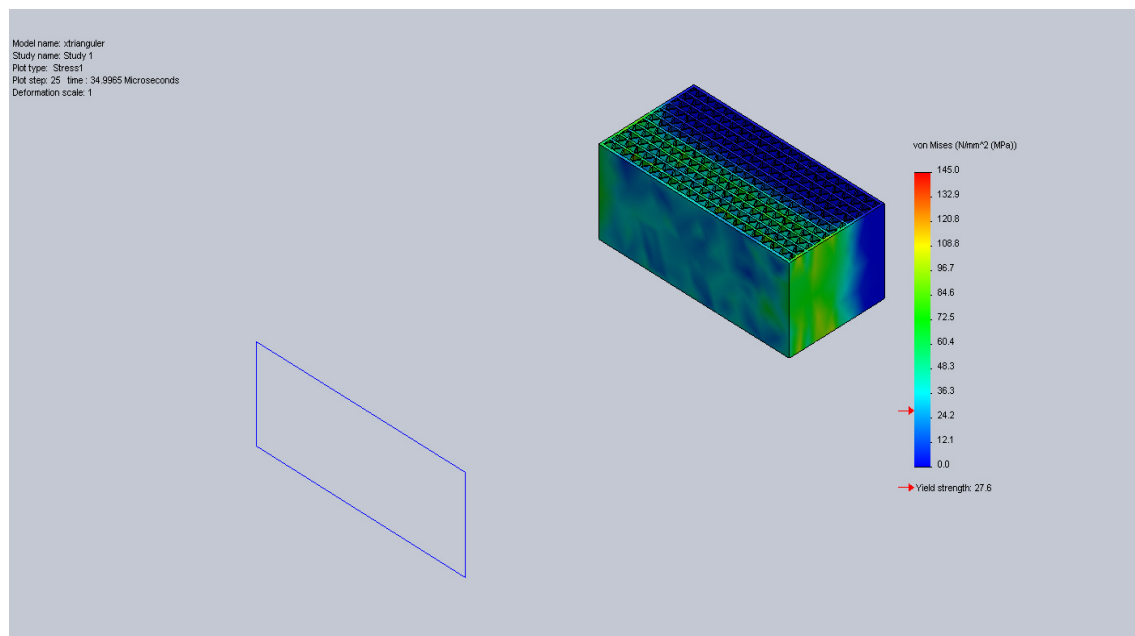

Fig 15: Von misses stress value, Min = 0.000854152 N/mm², Max = 145.002 N/mm²

5.0 Results

Name	Material	Von-misses stress In (N/mm ²)	Displacement in (mm)	Strain
Hexagonal	E-Glass	826.247	0.98144	0.0107664
	S ₂ -Glass	3561.1	0.544576	0.00331992
	Aluminum	842.841	0.981015	0.0121315
Square	E-Glass	141.632	0.200035	0.001330533
	S ₂ -Glass	281.863	0.0428777	0.000248751
	Aluminum	131.796	0.199973	0.0015333
Triangular	E-Glass	138.738	0.175346	0.00133339
	S ₂ -Glass	420.233	0.0733271	0.000351508
	Aluminum	141.817	0.175295	0.00152341
Cross-Triangular	E-Glass	151.585	0.175132	0.00148002
	S ₂ -Glass	414.289	0.0542841	0.000378127
	Aluminum	145.002	0.175229	0.00177581

6.0 Conclusion

The honey comb textile impact barriers having delaminating problem. In this different composite structures are validated to overcome the above said problem. Initially literature survey was done on impact barrier and textile structures, in the next step 3D models (honey comb, square, triangular and cross triangular) are prepared to carry out the impact test. Impact test is conducted on honey comb structure to evaluate the results. And also impact test is conducted on new structures to validate the designs. Generally aluminum alloy is used to manufacture impact barrier and its core structure. As per the analytical results obtained from impact analysis square type with s₂-glass is the best replacement for honey comb textile technology.

Reference

1. Kumaraj MH, Singh SS, Singh S, Firdyal JS. A: Study of selected volleyball skills in relation to specific strength; stature, age sports sciences 2014; 27(1).
2. Rathour. A comparative study of selected motor fitness variables of students study studying at senior secondary schools of rural and urban area. 2003; 21.
3. Devi. A comparative study of physical fitness and psychological traits of tribal and non – tribal high school boys and girls 2000; 25.
4. Verma KK. A comparative study of adjustment and physical fitness variables of Hockey, Volleyball and basketball women players,” research annual for movement 1999; 16(1).
5. Gahlawat OP. Analysis of physical fitness components and socio economics status of the wrestler in Harysna,” Ph.D. thesis, K.U.K 1993.
6. Tyagi. Physical Fitness Norma of Delhi State School boys and Girls, 1993; 30.
7. Josepl BK. Relationship of power, agility, flexibility and measurement of selected body segments to volleyball playing ability, unpublished master’s thesis, Jiwaji University, 1989.
8. Clark R, Opplinger BA, Mayhew JL, Haywood KM. Strength, Flexibility and Body composition difference

between, age group sheimmers and non – swimmers. Australian Journal of Science and Medicine in Sports 1986; 18(2).

9. Narain J. Kinanthropometric study of Indian Volleyball players of Different levels of competition, Unpublished, Thesis, Master’s course of sports, N.I.S., Patiala, 1985.
10. Upton SJ, Hagon RD. Comarison of Physiological profile of Middle age women Distance Runner and Sedentary women 1983; 83-84.
11. George LR, Nequin ND. Physiological Profile of Two Champion of Ulteramarathoner. The Physician and Sports Medicine 1983; 63.
12. Mangla RN. Comparative study of physical and physiological variables of swimmers, badminton players and gymnasts. A thesis submitted to Netaji Subhash N.I.S. Patiala, 37.