



IJMRD 2015; 2(3): 842-844
www.allsubjectjournal.com
Received: 11-03-2015
Accepted: 29-03-2015
e-ISSN: 2349-4182
p-ISSN: 2349-5979
Impact Factor: 3.762

Kunal Dhadse
B.tech, Civil Engineering,
SRM University

Shubham Mishra
B.tech, Mechanical
Engineering, SRM
University

Learin Mathew
B.tech, Civil Engineering,
SRM University

Shubham Bhatt
B.tech, Civil Engineering,
SRM University

Gyroscopic Damping of Wind Vibration for Skyscrapers

Kunal Dhadse, Shubham Mishra, Learin Mathew, Shubham Bhatt

Abstract

Limitation in building design due to high wind velocities is always a prime problem for engineers. Prime concern is safety for skyscrapers while maintaining architectural identity. The factors like wind currents and earthquakes make it difficult for designing high rise buildings. Various kind of vibrations are created in upper region of buildings subjected to higher wind load. Various methods are adopted to damp these vibrations, for example *Tuned Mass Dampers* are used in Taipei 101 in upper floors to damp wind vibrations. These methods have limitation for higher cost and lower range for vibrations. Additional design need to be provided to make a self-damping system. Our proposed idea is to create an advanced *self-stabilizing Gyroscopic Damping* system that could be flexible and scalable for any wind load and vibration at any height. The system would be a set of giant gyroscopes tuned to provide an excess inertia to the top floors against wind, concept of angular momentum is adopted to redirect the moment created by wind load to a safe vertical axis.

Keywords: Wind Load, Wind Vibrations, Vibration Damping, Gyroscopic Damping, Fly wheels, Tuned Mass Dampers.

1. Introduction

Gyroscope is a mechanical device which consist of a flywheel shielded from outside, on a smooth bearing. When the wheel is rotated about the bearing axis then the flywheel gains an *Inertia* along the axis of rotation. This happens due to the angular momentum generated along the wheels axis of rotation. This allows gyroscope to balance out its weight on one point, regardless of the non-symmetrical position on the ground. It also gains an ability to retain its initial position and balance out any external forces applied on it. This self-stabilizing ability makes it a potential vibration damper. A vertical axis of rotation is found to be most stable configuration for gyroscope. Using a number of gyroscope with controllable axis of rotation we can balance them with respect each other such that resultant of their angular momentum directly coincides with the vertical axis. Introduction of external momentums caused by wind load and earthquakes, the position of axis of rotation along with angular momentum can be changed to new configuration to again attain an exact vertical axis of rotation.

2 Design of Gyroscope

Gyroscope is designed to have controllable axis of rotation using hydraulic jack system. The resultant of angular momentum caused by wind with the gyroscopic angular momentum thus can be controlled. The higher value of M_1 will reduce the angle made by the resultant angular momentum with the vertical. A set of such gyroscopes with high moment of inertia can be programmed to balance out any angular momentum dis-balance, either by wind load or by earthquake. A combination of such variable axis flywheel gyros can together damp any kind of vibration in the structure of installation.

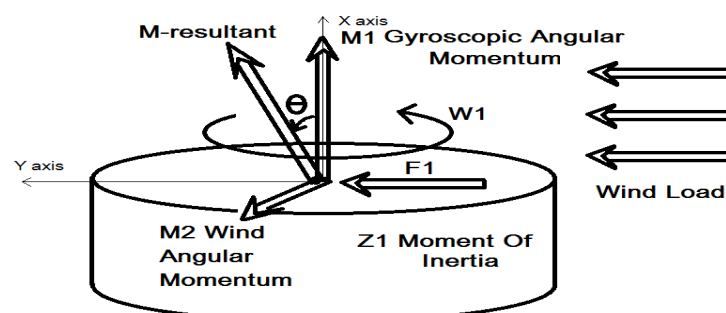

Correspondence:
Kunal Dhadse
B.tech, Civil Engineering,
SRM University

Above figure shows a gyroscope subjected to high wind loads. The M1 represents the flywheel angular momentum, while M2 represents the wind angular momentum by the Wind Load-F1. The resultant caused by these two combination is inclined at an angle from the vertical axis. Z1 represents the moment of inertia of the flywheel. W1 is the anticlockwise angular velocity of the flywheel. Due to rotation kinetic energy an angular momentum M1 is induced in the gyroscope. This axis of rotation is now with an extra inertia or resistance towards any external force.

3 Multiple Gyro Resultant

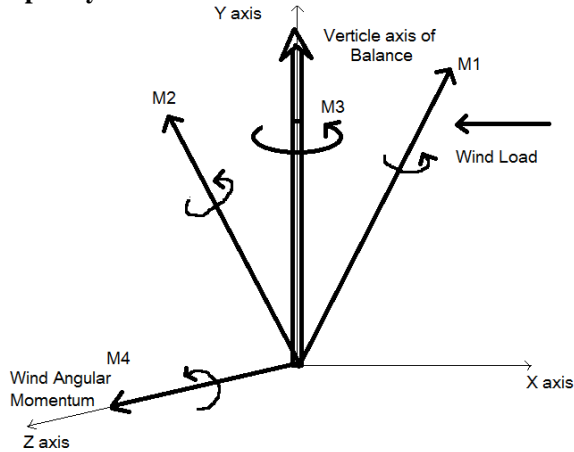

Explanation- Considering the wind angular moment to be on Z axis, an internal angular moment of resistance is needed to redirect the resultant in Y axis i.e. the stable axis for a building. These internal moments are provided by two gyroscopic combination in the above demonstration. Angular Moments M1 & M2 along with wind moment M4 yields out the resultant M3 along the Y axis. This can be easily calculated by the vector addition method for three vectors originating from a point in space.

$$\vec{M1} + \vec{M2} + \vec{M4} = \vec{M3}$$

$$(X1\hat{i} + Y1\hat{j}) + (X2\hat{i} + Y2\hat{j}) + (X4\hat{i} + Y4\hat{j}) = (Z3\hat{k})$$

M1, M2 & M4 are the balancing angular momentum combinations which satisfies the above equation. The M3k is the resultant angular momentum which has zero components along x-axis and y-axis. It has purely directed towards z-axis. The vertical axis of building is directly coinciding with the resultant angular momentum axis. This configuration will provide stability against any wind moment M4. Additional vibrations created by the earthquakes that are temporary but have high amplitude can also be balanced out using tilt sensors or vibration measurement sensors which will process the incoming vibration and find analytically the optimum configuration of flywheels to balance out the resulting angular momentum caused by these agencies.

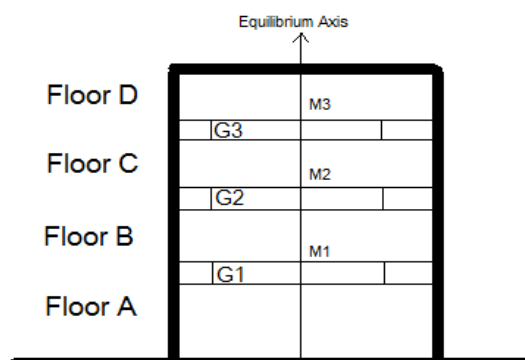

4 Design Specifications

Gyroscopes will be made up of high density carbon steel prefabricated detachable components. It will be mounted on a free axel with smooth bearings. The axis of the flywheel will be powered by a electromechanically operated motor transmitting sufficient power by a gear chain. The axis of rotation is controllable using hydraulics jacks supporting four supports of the flywheel. These units will be able to control the direction of the angular momentum caused by thee gyroscopes. Suitable configuration processed by computes will be adopted on regarding the given vibration characteristics.

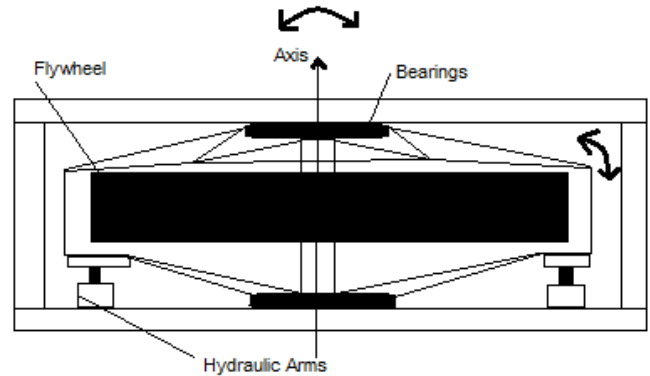

Hydraulic Arms-The axis of the angular momentum can be controlled by the hydraulic arms. These hydraulics arms will not alter the rotation speed of flywheel, they also not alter any changes in the rotational energy of the gyroscope; but, they will alter the direction of this angular energy into desirable axis such that the resultant axis of angular momentum including that of wind vibration and earthquake vibrations coincide with the axis of equilibrium or vertical axis. A combination of these gyro units can contain enough angular momentum such that they can influence high wind vibrational forces into the favor of buildings safety. Tendency to balance itself on one particular axis is intrinsic property of a gyroscope, it automatically provide resistance towards any changes in its axis of angular momentum. Using these properties a suitable unit can be produced with scalable design to make possible the construction of skyscrapers to height beyond today's limits.

5 Operating Specifications

The size of each Gyro unit depends purely on the floor size of the building. It will be installed in a middle part of the floor. The energy stored in a flywheel is directly proportional to the square of the angular speed of rotation of the flywheel. So regardless of the size of flywheel a desirably large amount of angular momentum can be stored in each gyro unit. Altering the angular speed provide us with desirable angular momentums. Depending on the wind vibrations and magnitude of these forces each unit can be synchronized with accuracy using sensors that records vibrations produced and help the system to counter balance these vibrations by pointing the resultant angular momentum to the vertical axis. This system will lose energy on regular basis due to bearing friction loss and other losses in adjusting the axis of angular momentum. Overall energy consumption will be equal to the loss in angular energy plus the operating energy to damp vibrations. These losses cannot be avoided but use of non-renewable energy sources with proper storage system can be adapted. Losses due to friction will be very less and will tend to reduce the angular speeds of the flywheels. These losses can directly be compensate by powering the wheel with a constantly rotating motor with proper gear chains to transfer the power in such amount that it compensate for the bearing friction losses.

Acknowledgment

We wish to thank our mentors and college for supporting us in completing our work regarding Vibration Damping in skyscraper due to wind using Gyroscopic Mass Damper Mechanism. We also wish to thank our parents for providing us with assets that helped us completing research regarding this concept.

References

1. P. Dallard, A. I. Fitzpatrick, A. Flint, S. Le Bourva, A. Low, R. Smith and M. R. Willford, "The London Millennium Footbridge," *The Structural Engineer*, Vol. 79, No. 22, 2001, pp. 17-33.
2. Saidi, "Development of a Viscoelastic Tuned Mass Damper to Reduce Walking Induced Vibrations in Building Floors," Thesis of Doctor of Philosophy, Swinburne University of Technology, Melbourne, 2012.
3. J. E. Campuzano, R. Castro, S. M. Avila and G. Doz, "Platform for Dynamic Tests: Preliminary Studies, Design and Construction," *Revista Ibracon de Estruturas e Materiais*, Vol. 6, No. 1, 2013, pp. 55-74. doi:10.1590/S1983-41952013000100004
4. T. T. Soong, G. F. Dargush, "Passive Energy Dissipation in Structural Engineering," John Wiley & Sons, Chichester, 1997.
5. W. D. Varela, "Modelo Teórico Experimental para Análise de Vibrações Induzidas por Pessoas Caminhando Sobre Lajes de Edifícios," Ph.D. Thesis, COPPE/UF RJ, Rio de Janeiro, 2004.
6. D. V. F. Lima, "Controle de Vibrações Induzidas em uma Laje de Academia de Ginástica com a Utilização de Amortecedores de Massa Sintonizados," Master Thesis, Universidade de Brasília, Brasília, 2007.
7. M. Setareh, J. K. Ritchey, A. J. Baxter and T. M. Murray, "Pendulum Tuned Mass Dampers for Floor Vibration Control," *Journal of Performance of Constructed Facilities*, ASCE, Vol. 20, No. 1, 2006, pp. 64-73. doi:10.1061/(ASCE)0887-3828(2006)20:1(64)
8. M. Setareh, J. K. Ritchey, T. M. Murray, J. H. Koo and M. Ahmadian, "Semiactive Tuned Mass Dampers for Floor Vibration Control," *Journal of Structural Engineering*, ASCE, Vol. 133, 2007, pp. 242-250.