



Volume: 2, Issue: 9, 431-436  
Sep 2015  
www.allsubjectjournal.com  
e-ISSN: 2349-4182  
p-ISSN: 2349-5979  
Impact Factor: 4.342

**Anshuman Pradhan**  
Scholar, Dept. of Mechanical  
Engg. Centurion University  
of Technology & Management  
Bhubaneswar, India

**Neelam Kumar Verma**  
Asst. Prof. Dept. of  
Mechanical Engg.  
Centurion University of  
Technology & Management  
Bhubaneswar, India

**Correspondence**  
**Anshuman Pradhan**  
Scholar, Dept. of Mechanical  
Engg. Centurion University  
of Technology & Management  
Bhubaneswar, India

## Design of 3 DOF articulated robotic arm with virtual reality toolbox

**Anshuman Pradhan, Neelam Kumar Verma**

### Abstract

This paper presents an approach based on Virtual Reality Toolbox to design a Three DOF articulated Servo Robotic Arm. This approach was successfully tested during the simulation period. The Robot Body, Fore arm model has been shown with control sub system development, which may be implemented in real hardware for various industrial applications.

**Keywords:** Servo Robot, Articulated, MATLAB, SIMULINK, Virtual Reality Toolbox

### I. Introduction

The word “robot” (from the Czech word “robota” for forced labor or serf) was used for the first time in a play called “R.U.R” (Rossum’s Universal Robots) by the Czech dramatist Karel Capek. In the 1920 science fiction play, which portrayed robots as intelligent machines serving their human makers, the plot ended dramatically. Robots took over the world and destroyed humanity. This scenario is far from reality! Today industrial robots and robotic systems are key components of automation. More than 1.1 million industrial robots are operating in the factories all

### Over the world

- Improving quality of work for employees
- Increasing production output rates
- Improving product quality and consistency
- Increasing flexibility in product manufacturing
- Reducing operating costs

Unimation, the company that developed the Unimate In 1956, George Devol and Joe Engelberger, established a company called Unimation, a shortened form of the words Universal Animation. Engelberger, a physicist working on the design of control systems for nuclear power plants and jet engines, met inventor Devol by chance at a cocktail party. Devol had recently received a patent called “Programmed Article Transfer.” Inspired by the short stories and novels of Isaac Asimov, Devol and Engelberger brainstormed to derive the first industrial robot arm, based upon Devol’s patent, called the Unimate. Programmed Article Transfer became the seminal industrial robot patent which was ultimately sub-licensed around the world. generator does not guarantee minimum cost as it may be located in an area where fuel cost is high.

Again if the plant is located far from the load center, Transmission losses may be considerably higher and hence the plant may be overly uneconomical.

Hence the problem is to determine the generation of different plants such that the total operating cost is minimum

In 2005 the IEEE Robotics and Automation Society (IEEE/RAS) and the International Federation of Robotics (IFR) agreed to jointly sponsor the Invention and Entrepreneurship in Robotics and Automation (IERA) Award. The purpose of this award is to highlight and honor the achievements of the inventors with value creating ideas and entrepreneurs who propel those ideas into world-class products. At the same time the joint disposition of the award underlines the determination of both organizations to promote stronger collaboration between robotics science and robotics industry.

### II. Proposed Method

The purpose of our work is to learn about the different components of robot and gain hands-on experience on a Servo Robot system. We will also show the control subsystem for the Robot

along with the Joint actuators, joint sensors, body and forearm operating principle of a robot.

The robot has three axes of rotation as shown in Figure 2. Additionally, there is a motion, Grab and Release, which is performed by the end effectors. All possible movements can be controlled using the interface program called control subsystem designed using MATLAB/SIMULINK. The robot can thus be programmed using a set of instruction to complete a certain task within its range of movement.

The robot has four basic components:

1. Manipulator
2. End Effectors (Hand)
3. Controller
4. Drives

For development of the 3axis articulated Servo Robot system, we have used MATLAB Virtual Reality Toolbox.

**Virtual Reality Toolbox Viewer**

The Virtual Reality Toolbox software contains a viewer as the default method for viewing virtual worlds. You can use this viewer on any supported operating system. For a list of supported operating systems, see System Requirements. This

section provides an overview of the features and controls of the viewer.

This section uses the *vrpend*, *vrplanets*, and *virtul1* demos to illustrate the viewer features:

1. Select a Virtual Reality Toolbox demo and type that demo's name in the MATLAB Command Window. For example:
2. `vrpend`  
The Simulink model is displayed. By default, the Virtual Reality Toolbox viewer for that model is loaded and becomes active. If the viewer is not displayed, double-click the VR Sink block in the Simulink model.
3. Inspect the viewer window.  
The Virtual Reality Toolbox viewer displays the virtual scene. The top of the viewer contains a menu bar and toolbar. The bottom of the viewer contains a navigation panel. These three areas give you alternate ways to work with the virtual scene.

By default, the Virtual Reality Toolbox viewer displays the virtual scene with a navigation panel at the bottom.

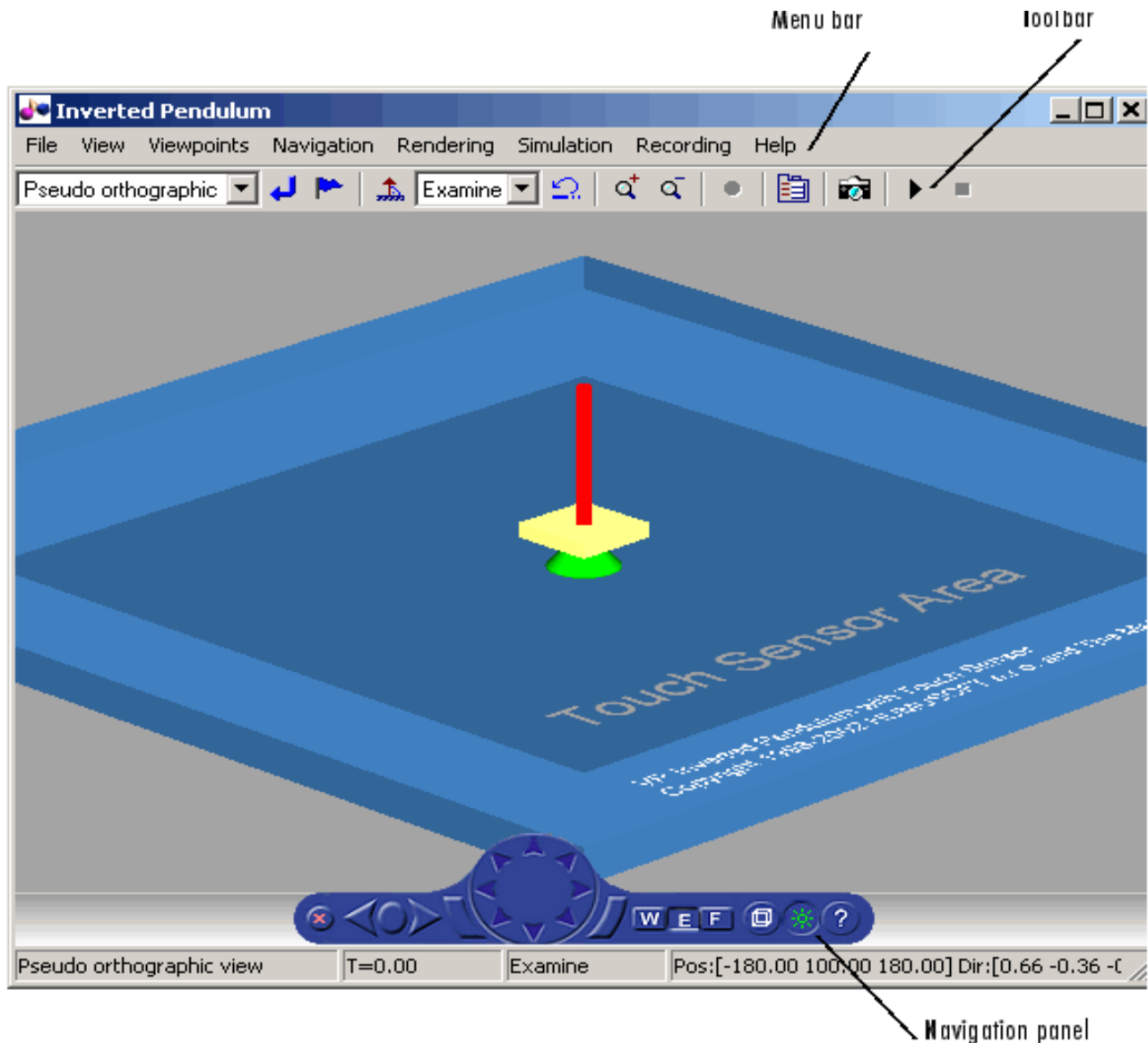

**Fig 1:** Matlab Virtual Reality Toolbox

**Outline of the Algorithm**

- 0: Choose MATLAB/SIMULINK as environment and take Virtual Reality Toolbox for design
- 1. Design the Control logic for the Robot with Simulink Predefined blocks

- 2. Define the Body,fore arm and finger parameters like mass,inertia tensor,coordinates of origin,centre of gravity.
- 3. Use the virtual reality subsystem to design the Robot Architecture

**III. Simulation Result**

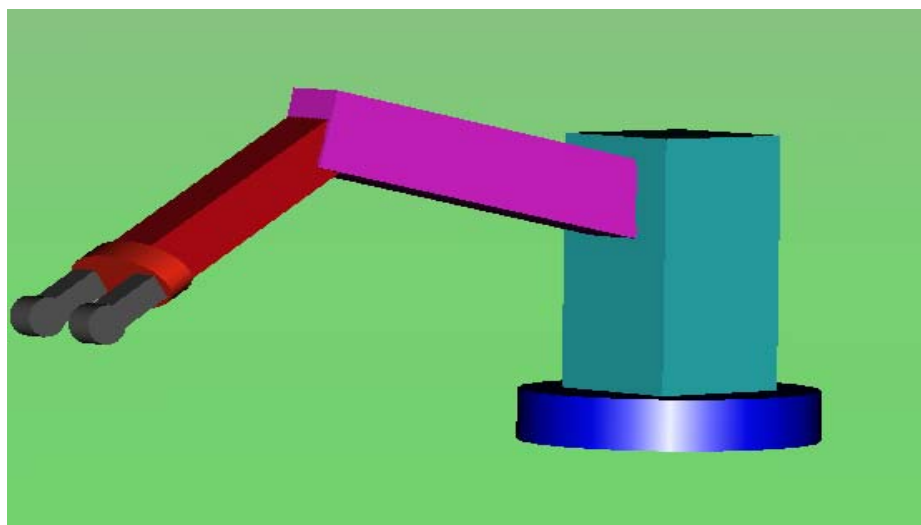
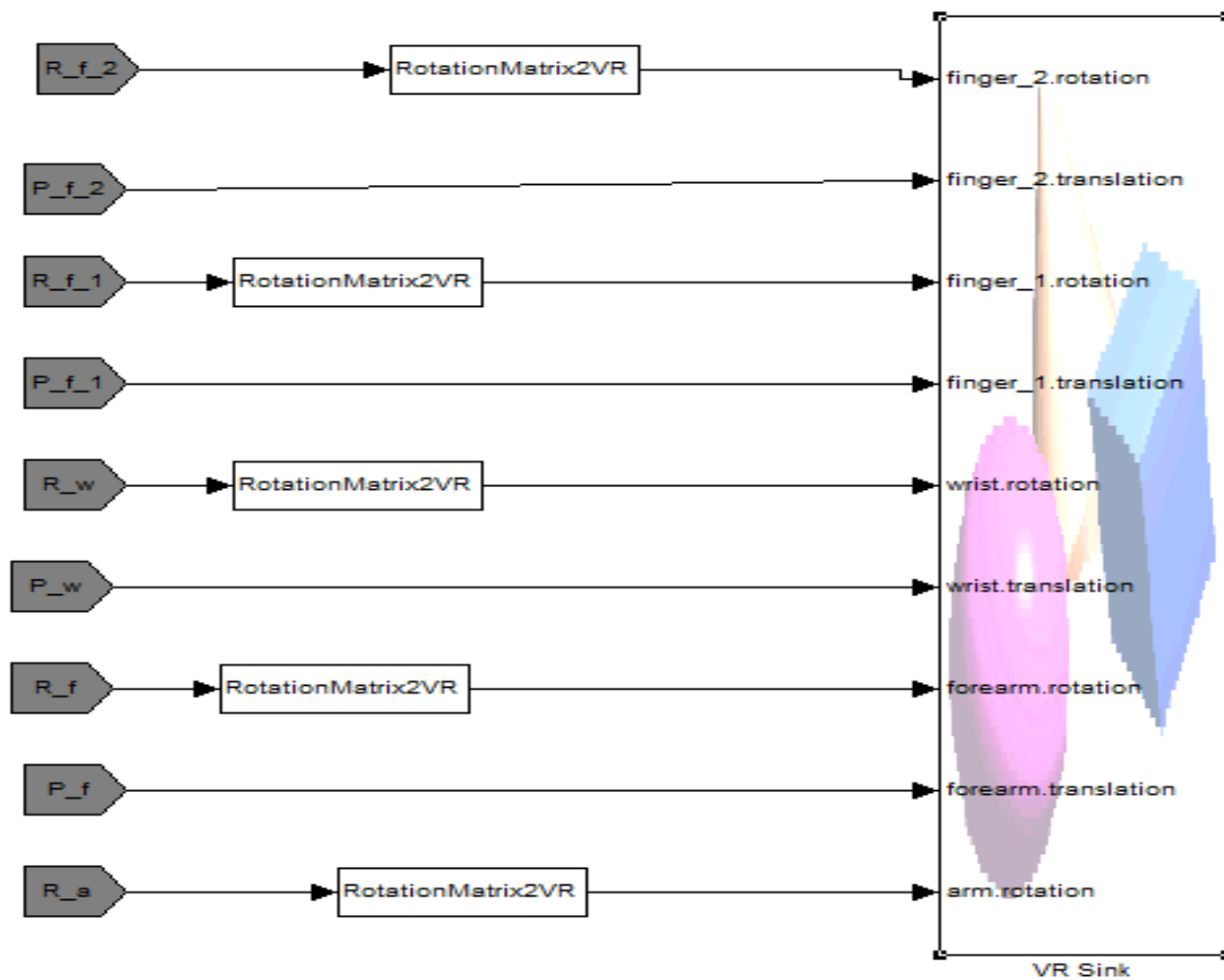
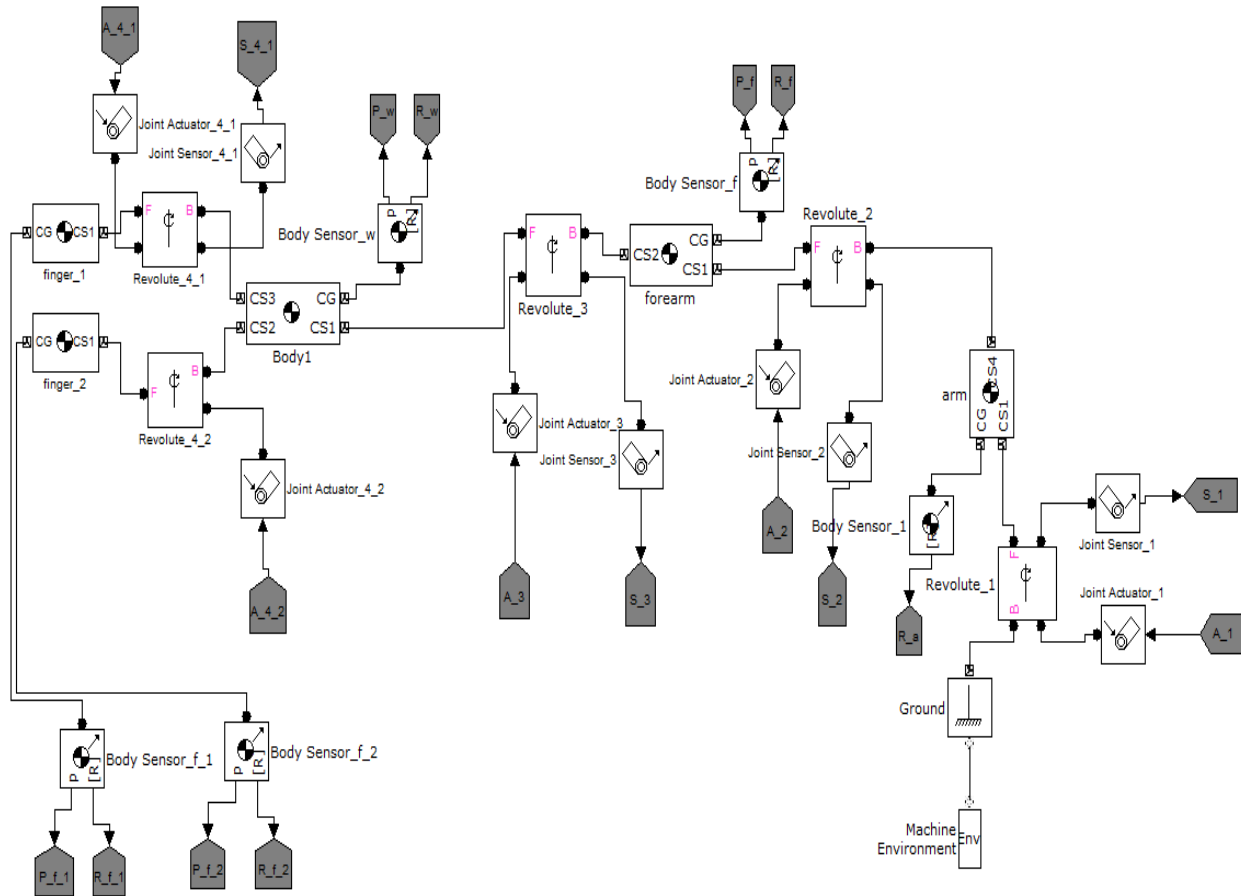

Fig 2: Three axis articulated servo robot arm

**Virtual Environment for Robot Simulation**



### Robot Internal Architecture



### Body Parameter

**Block Parameters: Body1**

**Body**  
 Represents a user-defined rigid body. Body defined by mass  $m$ , inertia tensor  $I$ , and coordinate origins and axes for center of gravity (CG) and other user-specified Body coordinate systems. This dialog sets Body initial position and orientation, unless Body and/or connected Joints are actuated separately. This dialog also provides optional settings for customized body geometry and color.

**Mass properties**

Mass:  kg

Inertia:  kg\*m<sup>2</sup>

Position    Orientation    Visualization

| Show Port                           | Port Side | Name | Origin Position Vector [x y z] | Units | Translated from Origin of | Component Axes of |
|-------------------------------------|-----------|------|--------------------------------|-------|---------------------------|-------------------|
| <input checked="" type="checkbox"/> | Right     | CG   | [0 0.1 0]                      | m     | CS1                       | CS1               |
| <input checked="" type="checkbox"/> | Left      | CS3  | [0 0.2 0.03]                   | m     | CS1                       | CS1               |
| <input checked="" type="checkbox"/> | Right     | CS1  | [0 0 0]                        | m     | Adjoining                 | World             |
| <input checked="" type="checkbox"/> | Left      | CS2  | [0 0.2 -0.03]                  | m     | CS1                       | CS1               |

|||

## Control Subsystem

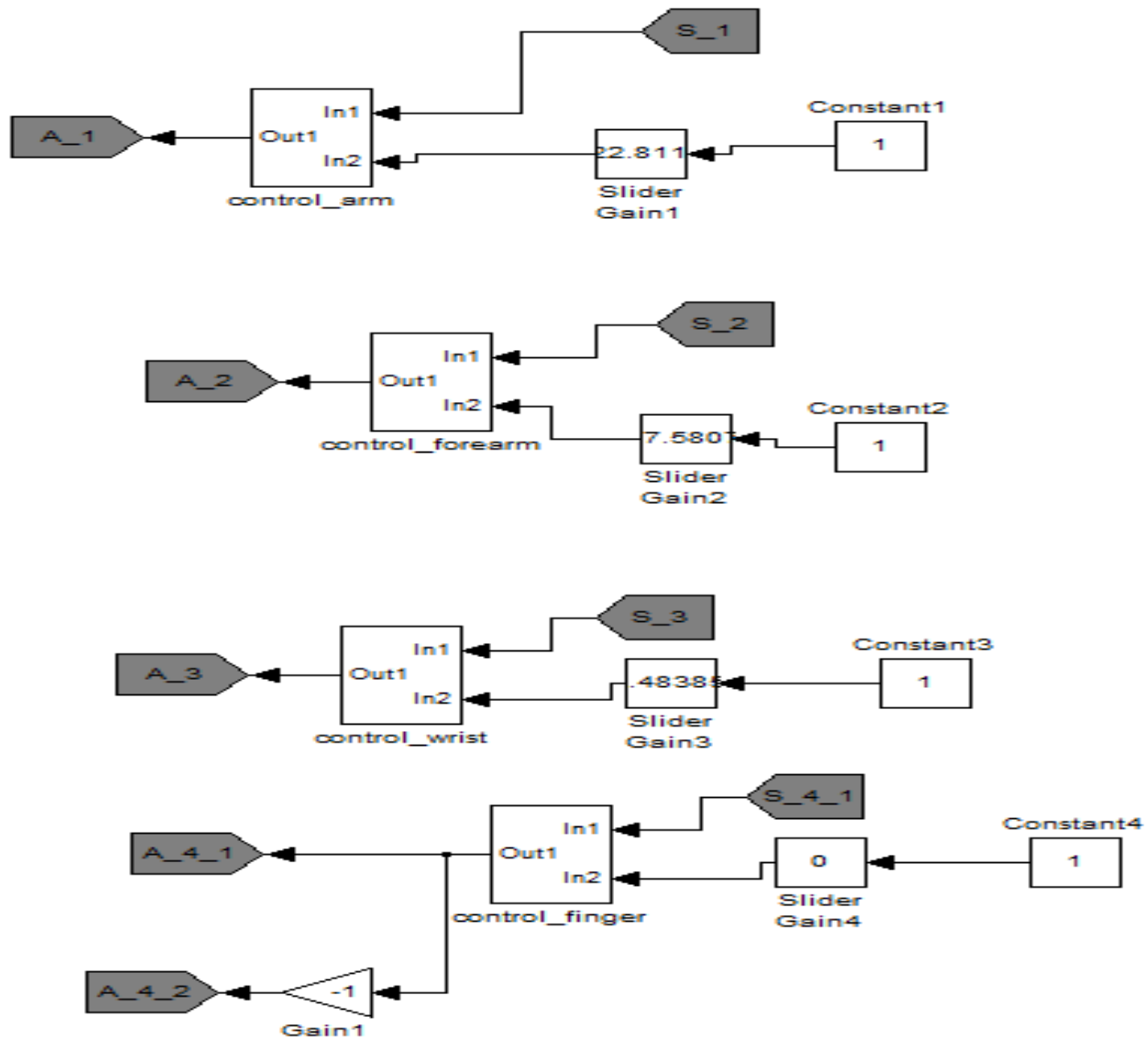

## III Conclusion

This paper has attempted to design a three degrees of freedom Articulated Robotic Servo arm with the help of MATLAB/SIMULINK Virtual Reality Toolbox. Various Body and Forearm along with finger parameters and sensors has been taken to design the arm with Matlab based control circuit to operate the system. The Work has a wide spread applications in industrial automations and may be further used for vision system integration for more advanced operations.

## IV References

1. Tsai LW. Kinematics of a three-dof platform with three extensible limbs. In Recent advances in robot kinematics Springer Netherlands, 1996, 401-410.
2. Dong-Sung Kim, Wook Hyun Kwon, Hong Sung Park. "Geometric Kinematics and Applications of a Mobile Robot", International Journal of Control, Automation, and Systems. 2003; 1(3):376-384.
3. Jae Hoon Lee, Bong Keun Kim, Tamio Tanikawa, Kohtarō Ohba. Kinematic Analysis on Omni-directional Mobile Robot with Double-wheel-type Active Casters, International Conference on Control, Automation and Systems, COEX, Seoul, Korea, 2007, 1217-1221.
4. Giovanni Indiveri. Swedish Wheeled Omnidirectional Mobile Robots: Kinematics Analysis and Control, IEEE transactions on robotics, 2009; 25(1):164-171.
5. Guzmán JL, Berenguela M, Rodríguez F, Dormidob S. An interactive tool for mobile robot motion planning, Robotics and Autonomous Systems 2008; 56:396-409.
6. Johann Borenstein. Control and Kinematic Design of Multi-Degree-of-Freedom Mobile Robots with Compliant Linkage, IEEE transactions on robotics and automation, 1995; 1:21-35.
7. Sascha A Stoeter, Nikolaos Papanikolopoulos. Kinematic Motion Model for Jumping Scout Robots, IEEE transactions on robotics 2006; 22(2):398-403.
8. Júlia Borràs, Federico Thomas. Kinematics of Line-Plane Subassemblies in Stewart Platforms, IEEE International Conference on Robotics and Automation, Kobe, Japan, 2009, 4094-4099.
9. Nilanjan Chakraborty, Ashitava Ghosal. Kinematics of wheeled mobile robots on uneven terrain, Mechanism and Machine Theory 2004; 39:1273-1287.



First Author: Mr. Anshuman Pradhan is currently pursuing M.Tech in Mechanical Engineering at CUTM, Bhubaneswar. His area of interest in Kinematics and Robotics Design.



Second Author: Mr. Neelam Kumar Gupta Currently working as asst. Prof in Dept. of Mechanical Engineering at CUTM, Bhubaneswar. His Area of Intrest is Robotics Design and Vision System.