

Renewable energy based elevator system by using BLDC motor: A review

Tarte Shital Ramdas

Department of Electrical Engineering, TSSM'S Bhivarabai Sawant College of Engineering and Research, Narhe, Pune, Maharashtra, India

Abstract

Recently, several measures are being taken to conserve energy without degradation in performance. To achieve notable energy savings in elevator systems, in this paper we develop and experimentally test and Operation of an elevator can be classified into four quadrant operation. Four quadrant operation of the proposed elevator system has also been indicated with the simulation results. To demonstrate the successful working of the proposal, a prototype elevator system has been designed and developed in the laboratory. Experiments have been conducted for the upward and downward movement of the elevator cabin with and without load.

Brushless Direct Current (BLDC) motors have secured a very significant space in the modern drives industry primarily due to the added benefits of a dc input system along with a brushless drive. Various advantages such as, high torque/current ratio, high power density and higher efficiency make these motors very suitable for replacing conventional motors in many systems. cite such advantages of a BLDC motor and also present a new simulation model that can be used for analysis and design of BLDC motors. Many studies have also been carried out to obtain higher efficiency and better control for BLDC motors. Further, owing to the ease of control and scope for regenerative braking, considerable amount of research has been carried out to incorporate BLDC motors in Electric Vehicles (EVs).

This prototype model consists of (i) mechanical components, such as worm gear, pulley and EC, etc., (ii) set of sensors for detecting floor position and rotor position of the motor, (iii) user command buttons, (iv) LED indicators and (v) BLDC motor along with power and control circuits.

Keywords: mechanical components, sensors, BLDC motor, control circuits

1. Introduction

An elevator is a vertical transportation vehicle used mainly for the transit of people and goods in high-raised buildings. Easy and efficient transportation within a building is of utmost importance, since the present day cities are considered to grow vertically. Generally an elevator uses a three phase induction motor to carry out the hoisting operation. However, considerable research has been carried out to replace the conventional motor to attain improved efficiency, reliability and speed.

Brushless Direct Current (BLDC) motors have secured a very significant space in the modern drives industry primarily due to the added benefits of a dc input system along with a brushless drive. Various advantages such as, high torque/current ratio, high power density and higher efficiency make these motors very suitable for replacing conventional motors in many systems. An elevator system deals with numerous signals and some of those are floor position signal, load sensor signal, door open signal, alarm, floor commands etc. Thus the controller designed for the elevator system needs to efficiently organize these signals for operating the system as per the user command. Ekanayake *et al.* have emphasized this aspect and suggested how a Field Programmable Gate Array (FPGA) controller can be beneficial for operating elevator systems. Yuhang *et al.* have implemented a six layer automatic elevator controller using an FPGA, highlighting the need and advantages. Joost *et al.* have shown the advantages of an FPGA based multiprocessor system in industrial applications. Wu *et al.* have developed a direct – drive servo

valve using an FPGA in the current controller and mentions why FPGA is superior over other controllers. Thus, owing to flexibility, durability and at-site re-configurability, FPGA controllers are gaining increased importance for many industrial applications. So, in this work, an FPGA controller has been designed and developed for the proposed elevator control.

2. BLDC motor control

BLDC motor control BLDC motor rotation is initiated by sequentially energizing the three phase winding of the stator with the appropriate polarity. This is achieved by controlling the sequence of conduction of the IGBTs in the inverter, based on the instantaneous position of the rotor. Table I shows the conduction of the IGBTs in the inverter for operating the BLDC motor in forward and reverse directions. It can be noticed from this table that, two switches conduct at any instant with one on the top leg and the other from the bottom leg.

3. Four quadrant operation of an elevator

The elevator system proposed in this paper operates in four quadrants depending upon the (i) relative weight of the EC and CW and (ii) direction of movement of EC. The four quadrant operation of the elevator system is shown in Fig.1. It is to be noticed that in quadrants I and IV, the EC is with passenger while in quadrants II and III it is empty. Upward motion of the EC corresponds to the forward rotation of the BLDC machine and reverse rotation is for downward motion

of EC. In the first quadrant, the net EC weight is assumed to be more as compared to the CW and EC needs to move upward. Hence, the BLDC machine operates as a motor (forward motoring) with torque and rotational speed in the same direction as indicated in Fig. 1. Similarly, the BLDC machine operates as a motor (reverse motoring) in the third quadrant as the net EC weight is less as compared to the CW and EC moves downward. In the second quadrant, the net EC weight is assumed to be lighter than the CW and EC needs to move upward. So, the BLDC machine acts as a brake (forward braking) with torque and rotational speed in the opposite direction along with the worm gear. The primary objective of worm gear in elevator system is to work as a natural brake such that the EC does not move due to the difference in net EC weight and CW with gravity. Thus, the presence of worm gear forbids any reverse mechanical power flow. If suitable gear arrangement is employed in place of worm gear then the BLDC machine can act as a generator (i.e., regenerative braking) in II quadrant. Similarly, the BLDC machine acts as a generator or brake (reverse braking) in the IV quadrant.

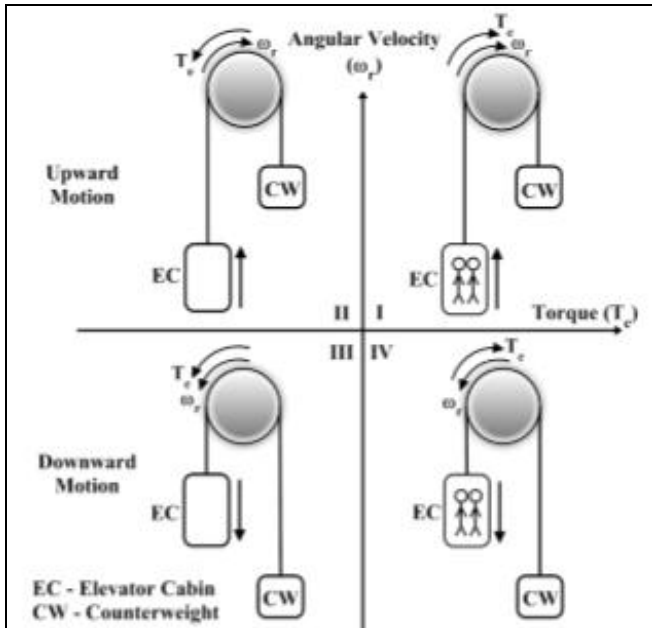

Fig 1: Four quadrant operation of an elevator system

4. RFID Operating Principle

RFID represent the way to identify objects using radio waves. The device that used for capture and transfer information is a

RFID reader. It is able to read data from a transponder. RFID reader will transmit the energy field that wakes up the tag and power up the chip to enable the transmission of the data. The tag also known as the transponder holds the data when the tag is interrogated by the reader. The most common tags today consist of an Integrated Circuit (IC) with limited memory which depend on the application. Basically, this project only required passive RFID tag to operate. Passive RFID tag does not need battery instead this tag obtain their operational power from harvesting the electromagnetic energy emitted from their reader. The tag temporary store the small amount of energy emitted from heir reader, convert it to DC power to power up their microchip and generate their response.

5. Microcontroller

Microcontroller is a compact stand alone computer which can optimized for control application. It contains processor core, memory and programmable input/output peripherals. Microcontroller can integrates additional elements which are read write memory for data storage purpose and the read only memory for program storage. This PIC16F877A model has been selected because the number of pins and ports which are appropriate for this project.

6. Motor Driver Circuit

A gate driver IC is used between the microcontroller and the gates of the MOSFETS for three reasons:

- To step up the 3.2V logic signal from the microcontroller to a 12V signal for the low side transistors in order to saturate the MOSFET
- To provide a charge pump circuit for driving the gate of the high side transistors to 12V above the voltage on the source pin in order to saturate the MOSFETS
- To provide shoot-through protection with programmable dead time for the three phase H-bridge Gate resistors between the output from the gate driver IC and MOSFET gate are used to slow the switching times of the transistors. This is to reduce the rate of change of current (di/dt) through the motor windings. The self-inductance of the windings causes an induced voltage across the winding that is proportional to the rate of change of current when the transistors are switched on and off. This induced voltage can cause the transistors to experience a voltage that exceeds the V_{dss} rating, causing them to blow. These gate resistors are arranged in a way to reduce ringing issues with the paralleled transistors.

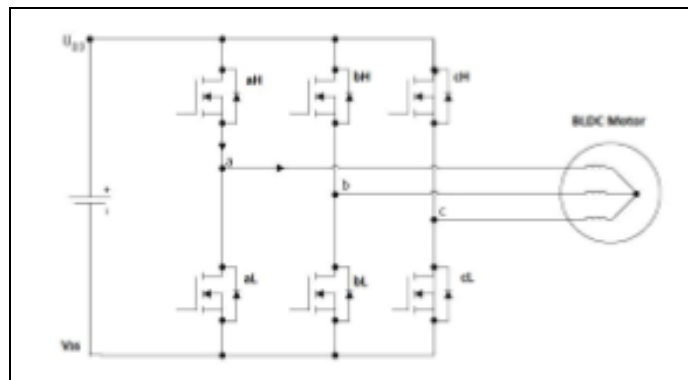

Fig 2: Three-phase H-bridge circuit for driving a BLDC motor

7. Results & Discussion

In general, the simulation results and the experimental results show that the energy savings is possible in elevator operation under variable speed algorithm. The amount of energy savings obtained in simulation is slightly different from the amount of energy savings obtained in the experiment with the model. One reason for the difference of results of simulation and the experiment may be the use of different type of energy form. In simulation, we considered the mechanical energy of the elevator system whereas in the actual experiment we measured the electrical energy. Also, the experimental model is for a Three floor building whereas the simulation model also three floor building.

Experiments have been conducted for various operating conditions on the prototype model in the laboratory with 60 V dc source. It has been observed that the dc input current to the inverter supplying BLDC motor decreases as the load on the cabin weight increases for downward motion and vice-versa for upward motion. Further, the experimental results obtained on the prototype system agree closely with the values obtained using MPLAB model of the proposed system.

In addition, the actual height of the elevator shaft and the actual weight carried were scaled down in the model with a ratio. All these factors may have led to some differences between simulation and the experiment. However, the percentage of electrical energy savings measured in the experiment is more than the percentage of mechanical energy savings obtained in simulation.

8. References

1. Dwijasish Das, Kumaresan N, Member IEEE, Nayanar V, Navin Sam K, Ammasi Gounden N. Development of BLDC Motor Based elevator System Suitable for DC Microgrid IEEE/ASME Transactions on Mechatronics 2015, 2016; 21(3).
2. Muhammad Z Hasan, Rainer Fink, Muthuvel Raj Suyambu, Manoj Kumar. Bask aran Dary James, Jesus Gamboa. Performance Evaluation of Energy Efficient Intelligent Elevator Controllers Electro/Information Technology (EIT), 2015 IEEE International Conference, 2015,
3. Rowe A, Gupta GS, Demidenko S. Instrumentation and Control of a High Power BLDC Motor for Small Vehicle Applications, Instrumentation and Measurement Technology Conference (I2MTC), 2012 IEEE International, 2012.